

SPECIFICATIONS:

UL Listed to CSA C22.2 No. 66.1, 66.2 and UL5085-1, UL5085-2.

Primary/Input: 480V, 60Hz, 87W, 0.18A @ Full/Rated Load.

Secondary/Output:

- Open Circuit= 245V ±2%, 2.90W
- Full/Rated Load= 230V ±2%, 75VA (75W/0.34A resistive load)

DC Resistance

- Primary (white-red): 184 ohms nominal.
- Secondary (white-black): 88 ohms nominal.

Dielectric Strength: Winding to Core 3000V, 60Hz, 1 sec.

Load Regulation: 7.5% typ.

Efficiency: 93% typ. @ 480Vin, 75VA load.

Insulation System: Class B (130°C).

Environmental Temperature Rating: -40°C to +60°C.

Surface Temperature (typ): 67°C @ 25°C Ambient, Full load.

MTBF (based on MIL Handbook 217F): Min 50 yrs @ rated specification.

Housing- Black Zytel FR50 (plastic)

Suitable for IP66 rated applications.

#18 awg Leads
out 6.0" minimum.

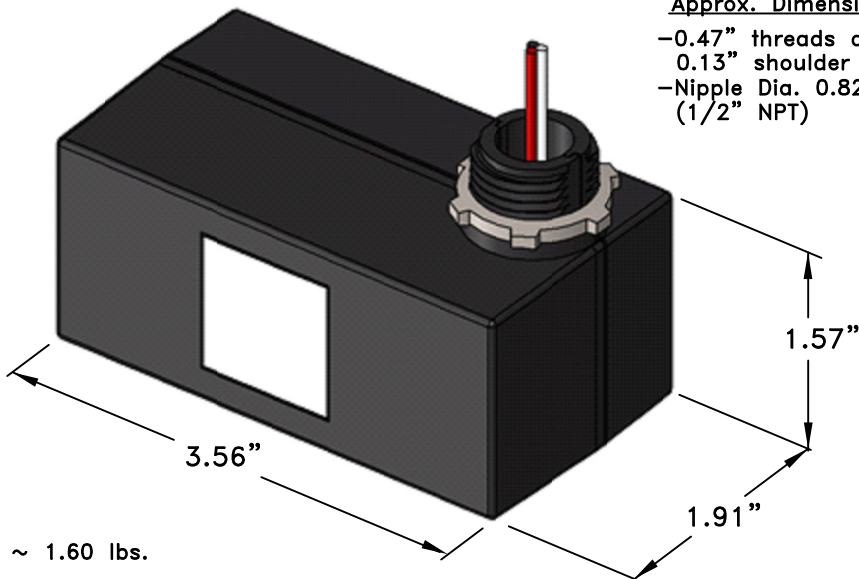

Weight ~ 1.60 lbs.

Approx. Dimensions

- 0.47" threads above
0.13" shoulder
- Nipple Dia. 0.82"
(1/2" NPT)

AUTOTRANSFORMER

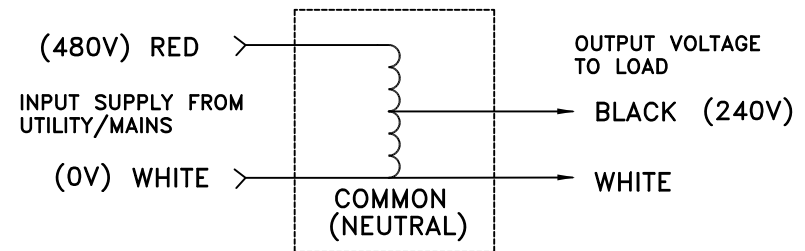

Note: "FB" version has an internal auto reset 110°C thermal protector in series with the "RED" input lead.

"EB" version does not have an internal fuse.

INSTALLATION INSTRUCTIONS:

Mechanical: This transformer is typically used for external assembly to a lighting fixture enclosure.

- Remove the metal lock-nut from the threaded nipple.
- Insert the threaded nipple and the lead-wires through a hole or standard knock-out in the fixture enclosure.
- Secure the transformer inside of the enclosure using the lock-nut on the threaded nipple; hand tighten.
- Note: Take care not to over-tighten the locknut to avoid damage to the housing.

Electrical: Connect the Red/White leads to the Supply and the Black/White leads to the Load per the AUTOTRANSFORMER drawing above.

- Note that the "White" lead is the Neutral and is common to both the Input Supply and Output to Load.

E359128



AUTOTRANSFORMER



TITLE:

DATE: 06/30/20

210099EB & 210099FB OUTLINE DRAWING

